

NO. A-22694-1

PUMP PERFORMANCE CURVES

TYPE Submersible Centrifugal Wastewater Pump	MODEL 150NH27.5 -61	FREQUENCY 60 Hz
--	---------------------	-----------------

CUSTOMER'S NAME _____

EQUIPMENT TITLE _____ NO. _____

	STANDARD SPECIFICATIONS	REQUIRED SPECIFICATIONS
DISCHARGE BORE	150 mm	mm
TOTAL HEAD	MAX 28.5 m	m
CAPACITY	MAX 2.65 m ³ /min	m ³ /min
MOTOR OUTPUT	7.5 kW	kW
PHASE x VOLTAGE	3 ϕ x V	ϕ x V
CURRENT	A	A
POLES / REVOLUTION	2 P / S. S. 3600 min ⁻¹	P / min ⁻¹
STARTING METHOD	DIRECT ON LINE	
INSULATION CLASS	F	

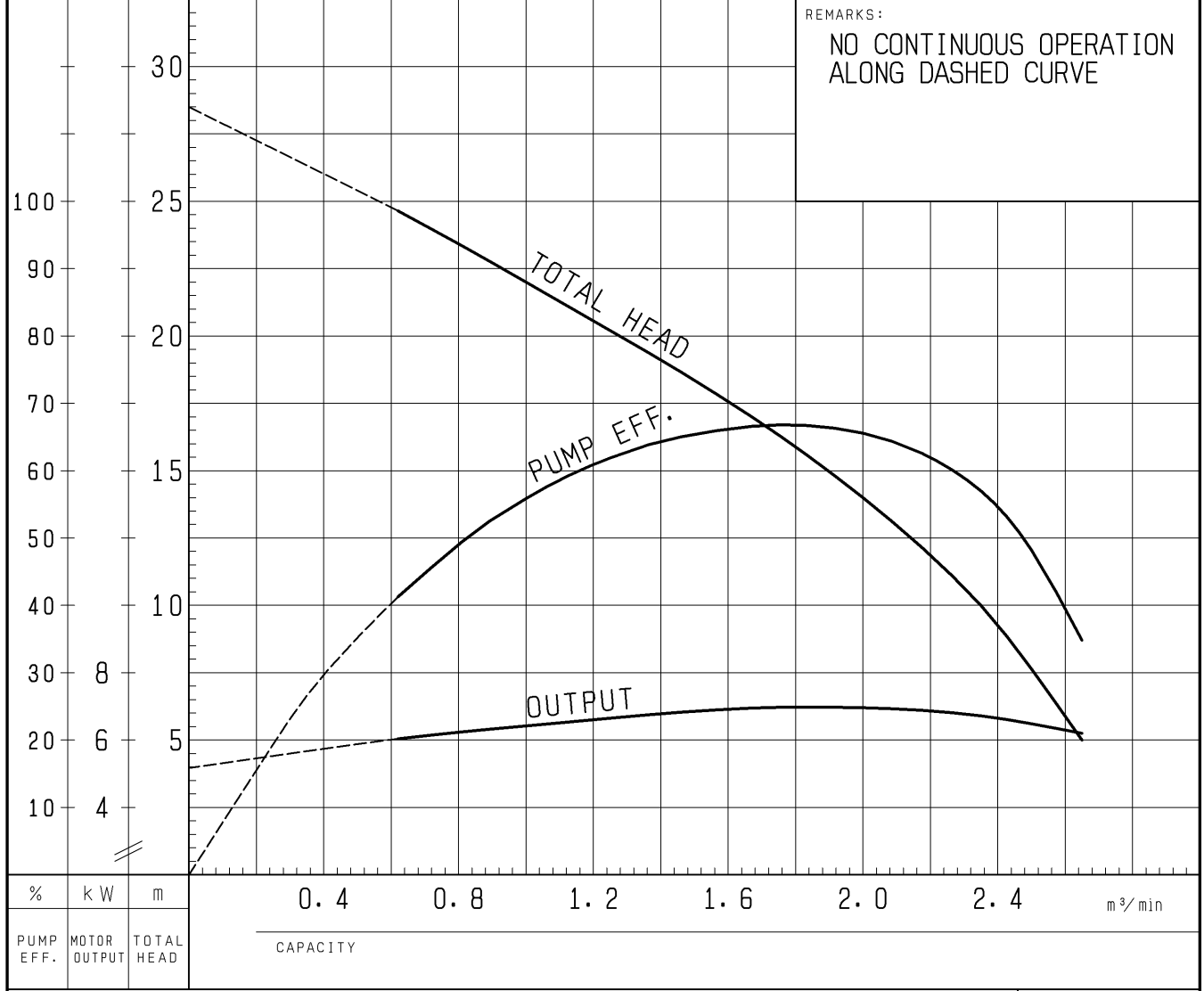

TSURUMI MFG. CO., LTD.

DIMENSION DRAWING		No.	No.	A-21966-2
TYPE	Submersible Centrifugal Wastewater Pump	MODEL	50/80/100NH25.5 -51/61 100/150NH27.5 -51/61	

MODEL	d	A	A1	A2	A3	B	D	D1	W1	W2	H	Approximate Weight (kg)
50NH25.5-51/61	50	497	116	205	303	185	266	123	450	153	790	90kg
80NH25.5-51/61	80	515	115	195	307	251	256	122	450	153	793	96kg
100NH25.5-51/61	100	569	128	209	336	292	281	141	500	192	835	105kg
100NH27.5-51/61	100	597	130	235	362	297	283	140	500	197	835	114kg
150NH27.5-51/61	150	720	153	245	427	335	310	168	510	214	850	140kg

※excluding cable

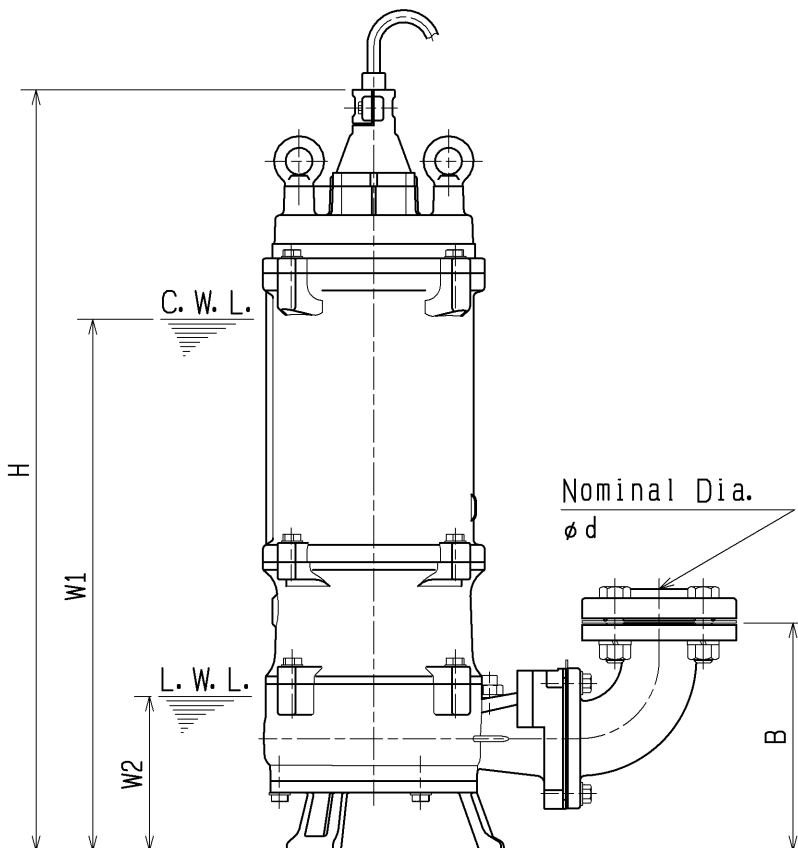
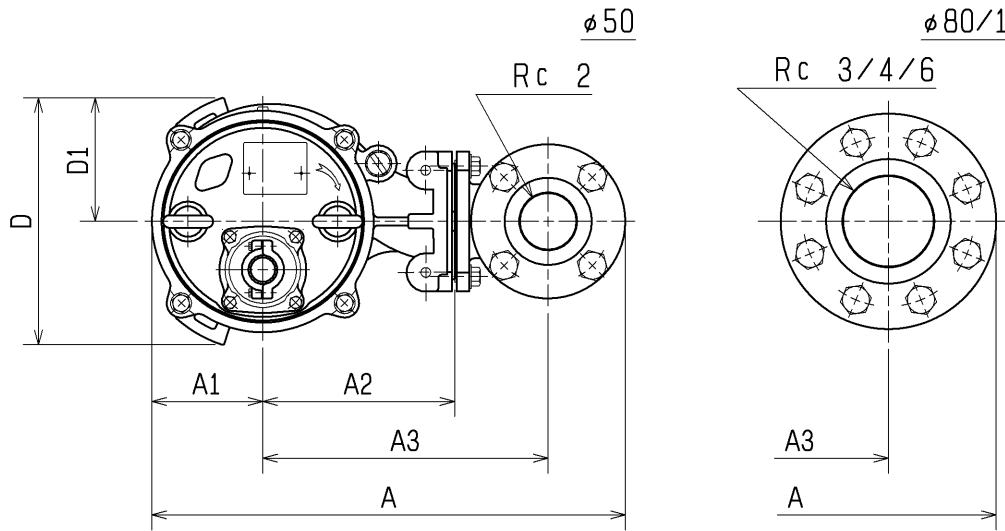

C. W. L. :Continuous running Water Level
L. W. L. :Lowest running Water Level

SECTIONAL DRAWING		No.	No.	A-21968-2
TYPE	Submersible Centrifugal Wastewater Pump	MODEL	50/80/100NH25.5 -51/61 100/150NH27.5 -51/61	

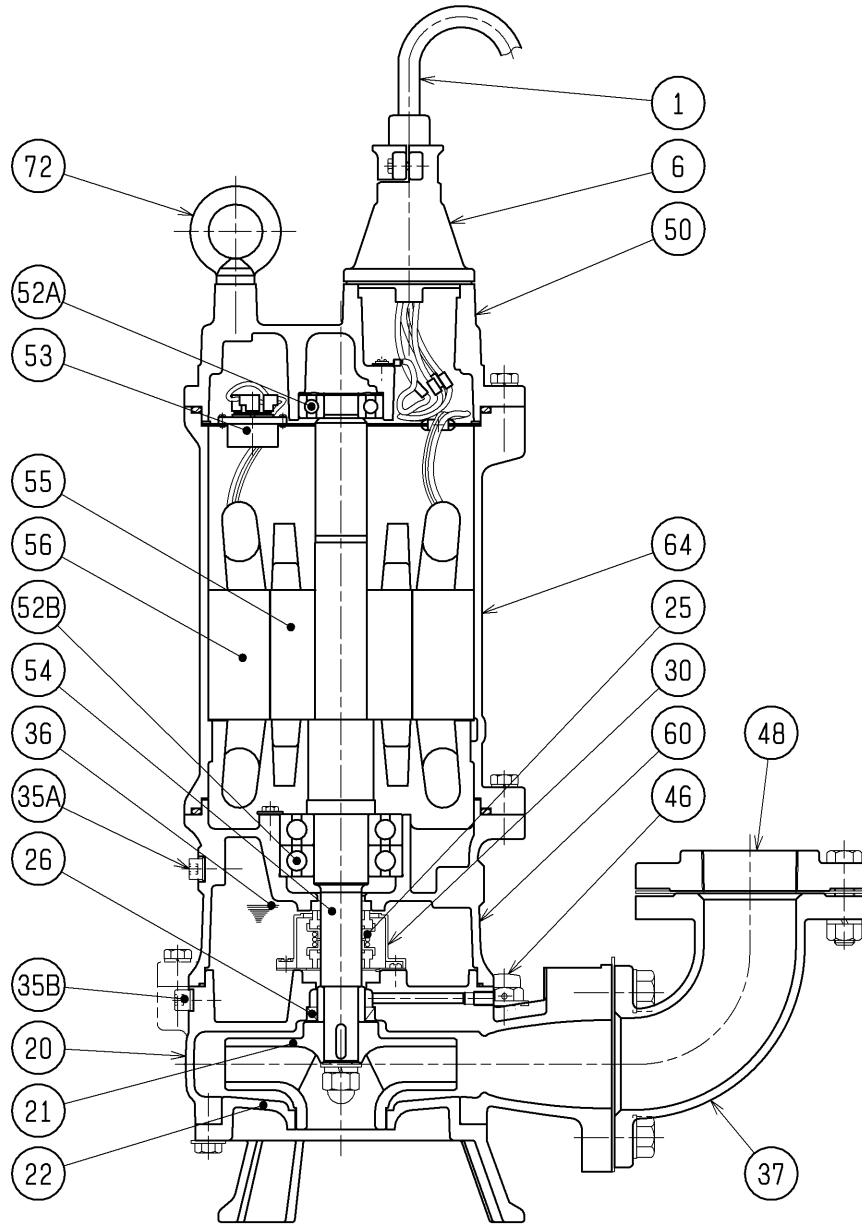

REQ. SPECIFICATION	

※ the wetted part

No.	DESCRIPTION	Q'TY	MATERIAL / NOTE	No.	DESCRIPTION	Q'TY	MATERIAL / NOTE
1	Cable	1	Chloroprene Sheath	48	Screwed Flange	1	Gray Iron Casting
6	Stuffing Box	1	Gray Iron Casting	50	Motor Bracket	1	Gray Iron Casting
20	Pump Casing	1	Gray Iron Casting	52A	Upper Bearing	1	6305ZZC3
21	Impeller	1	Gray Iron Casting	52B	Lower Bearing	2	6308ZZC3
22	Suction Cover	1	Gray Iron Casting	53	Motor Protector	1	
25	Mechanical Seal	1	φ30	54	Shaft	1	Stainless Steel 420J1(※)
26	Oil Seal	1	355010	55	Rotor	1	
30	Oil Lifter	1	Plastic	56	Stator	1	
35A	Oil Plug	1	Stainless Steel 304	60	Bearing Housing	1	Gray Iron Casting
35B	Oil Plug	1	Stainless Steel 304	64	Motor Frame	1	Gray Iron Casting
36	Lubricant		Turbine Oil (ISO VG32)	72	Eye Bolt	2	Carbon Steel
37	Discharge Bend	1	Gray Iron Casting				
46	Air Release Valve	1	Plastic				