

SPECIFICATIONS	Model	80C21.5	C-series
			1.5kW, 3-phase

<p>Type of Pump Submersible cast iron pump with a cutting device suitable for pumping sewage and wastewater</p> <p>Type of Fluid Sewage, wastewater, and water carrying solid matters</p> <p>Temperature: 0 to 40°C (High temperature model available on special request)</p> <p>Discharge Bore 80mm</p> <p>Motor Output 1.5kW</p> <p>Power Supply Three-phase</p> <p>Starting Method Direct on Line</p> <p>Motor Continuous-duty rated, dry-type induction motor</p> <p>Insulation Class: F Degree of Protection: IP68</p> <p>No. of Poles & Speed (Synchronous Speed) 2-pole, 3000/3600min⁻¹ (50/60Hz)</p> <p>Power Supply Voltages & Rated Currents</p> <table border="0"> <tr> <td>50Hz</td> <td>60Hz</td> </tr> <tr> <td>380V – 3.5A</td> <td>220V – 6.0A</td> </tr> <tr> <td>400V – 3.5A</td> <td>380V – 3.4A</td> </tr> <tr> <td>415V – 3.5A</td> <td>440V – 3.2A</td> </tr> </table> <p>Power Cable Sheath: PVC Standard Length: 6m 200 to 600V supply: 1 × 4 × 1.25mm², O.D. 11.1mm</p> <p>Dry Weight (excluding cable) Free Standing Type: 36kg Guide Rail Fitting Type: 34kg</p>	50Hz	60Hz	380V – 3.5A	220V – 6.0A	400V – 3.5A	380V – 3.4A	415V – 3.5A	440V – 3.2A	<p>Impeller Semi-open single-channel impeller for solid-handling design, dynamically balanced. A sintered tungsten carbide alloy edge is blazed on the impeller vane.</p> <p>Solids Passage 50Hz – 43 × 60mm 60Hz – 37 × 60mm</p> <p>Cable Entry with Anti-Wicking Block Watertight cable entry with strain-relief device. The anti-wicking block prevents water incursion due to capillary action should the power cable be damaged or the end submerged.</p> <p>Bearings Permanently lubricated, deep-groove, double-shielded C3 ball bearings</p> <p>Shaft 420 stainless steel</p> <p>Shaft Seal (Mechanical Seal) Furnished with a double-face mechanical seal located in oil chamber. Both upper and lower seal faces always run in a clean environment.</p> <p>Upper Seal Faces: Ceramic + Carbon Lower Seal Faces: SiC + SiC</p> <p>Oil Seal (Lip Seal) Used as a “Dust Seal”, it protects the mechanical seal from abrasive particles.</p> <p>OIL LIFTER (Patented) Equipped in oil chamber. It forcibly supplies lubricating oil to the mechanical seal and continues to supply the oil to the upper seal faces even if lubricant falls below the rated volume.</p> <p>Type of Lubricating Oil & Volume Turbine Oil (ISO VG32), 900ml</p> <p>Motor Protection Device A circle thermal protector built in the motor housing. Directly cuts the motor circuit if excessive heat builds up or an overcurrent condition occurs in the motor.</p>
50Hz	60Hz								
380V – 3.5A	220V – 6.0A								
400V – 3.5A	380V – 3.4A								
415V – 3.5A	440V – 3.2A								

Optional Accessories

Bend Set (Free Standing Type)

- Discharge Bend
- Screwed Flange

TOS/TS Set (Guide Rail Fitting Type)

- Duckfoot Bend
- Guide Support
- Guide Hook
- Lifting Chain 5m (with Shackles)
- JIS 10kg/cm² Screwed Flange (TOS Set only)

External Leakage Sensor

DIMENSION DRAWING		No.	No. A-11472-3
TYPE	Sewage Submersible Cutter Pump	MODEL	80C21.5 -52/62

Approximate Weight (※)
36kg
※excluding cable

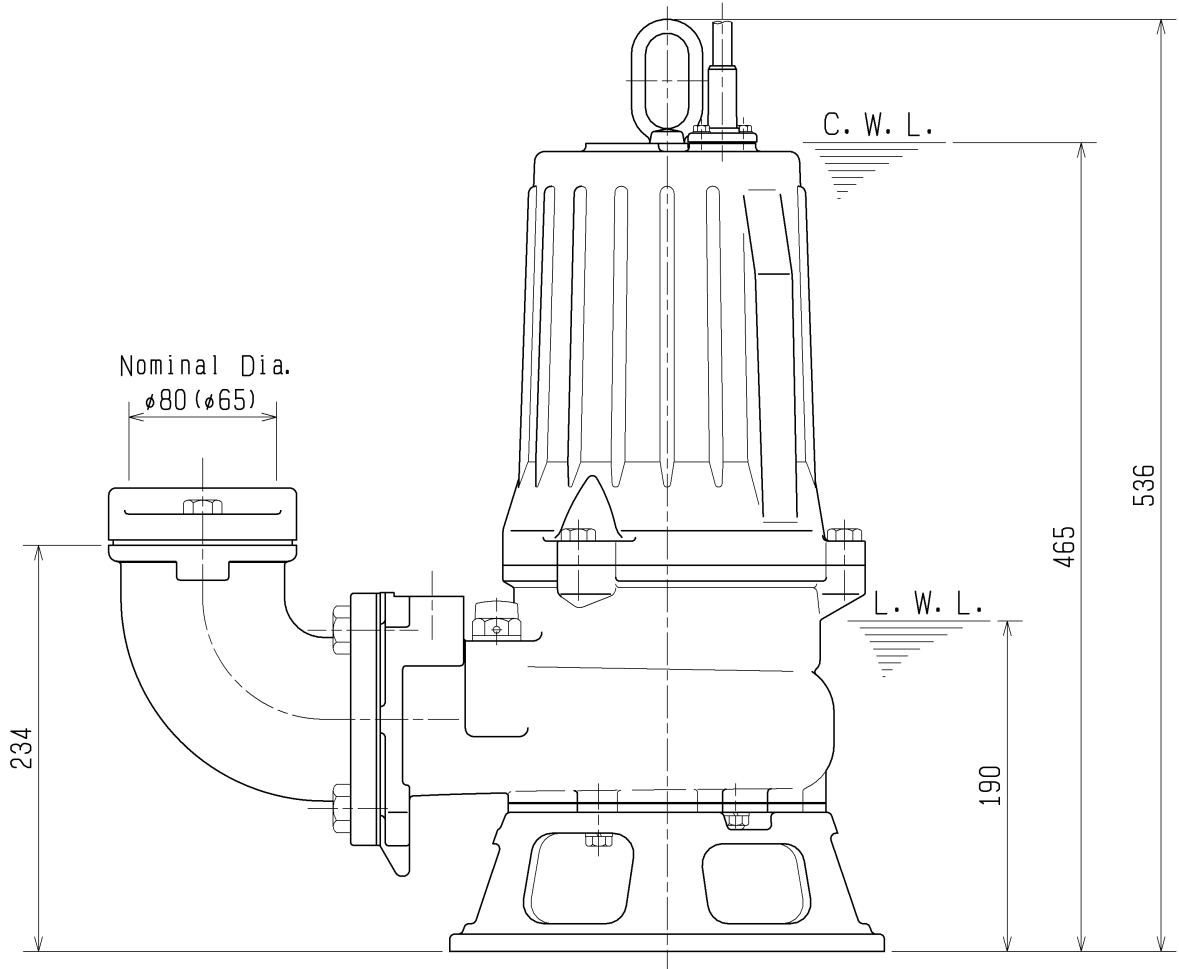
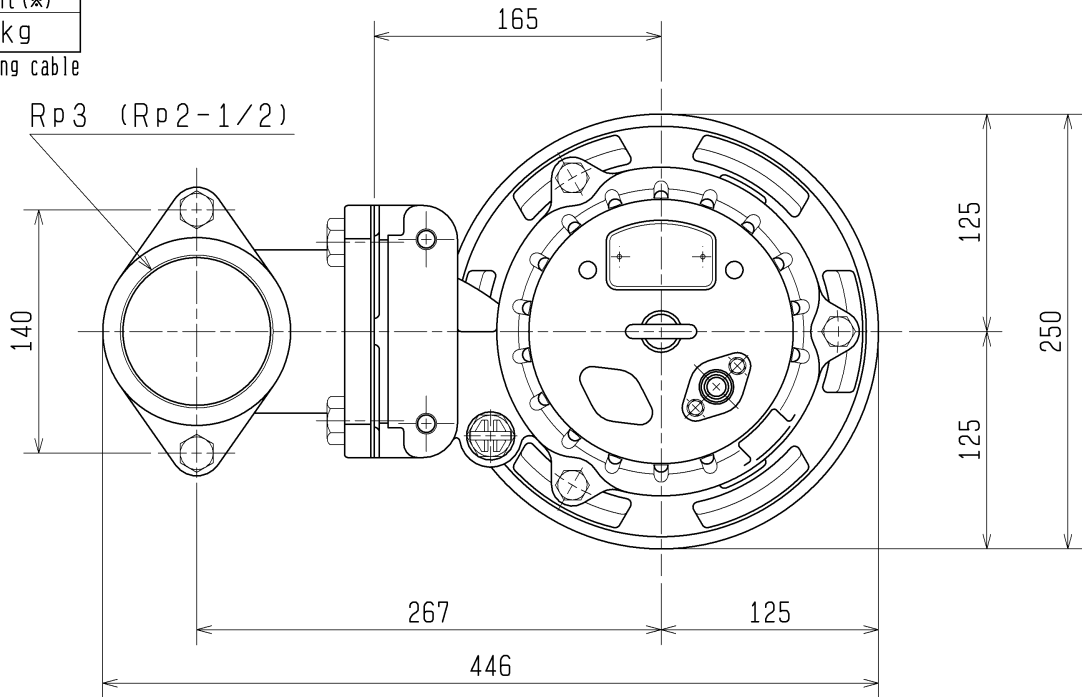

The Figure in () shows the dimensions of discharge Bore at Nominal φ65.

C.W.L. :Continuous running Water Level
L.W.L. :Lowest running Water Level

SECTIONAL DRAWING		No.	No. A-11475-5
TYPE	Sewage Submersible Cutter Pump	MODEL	80C21.5 -52/62

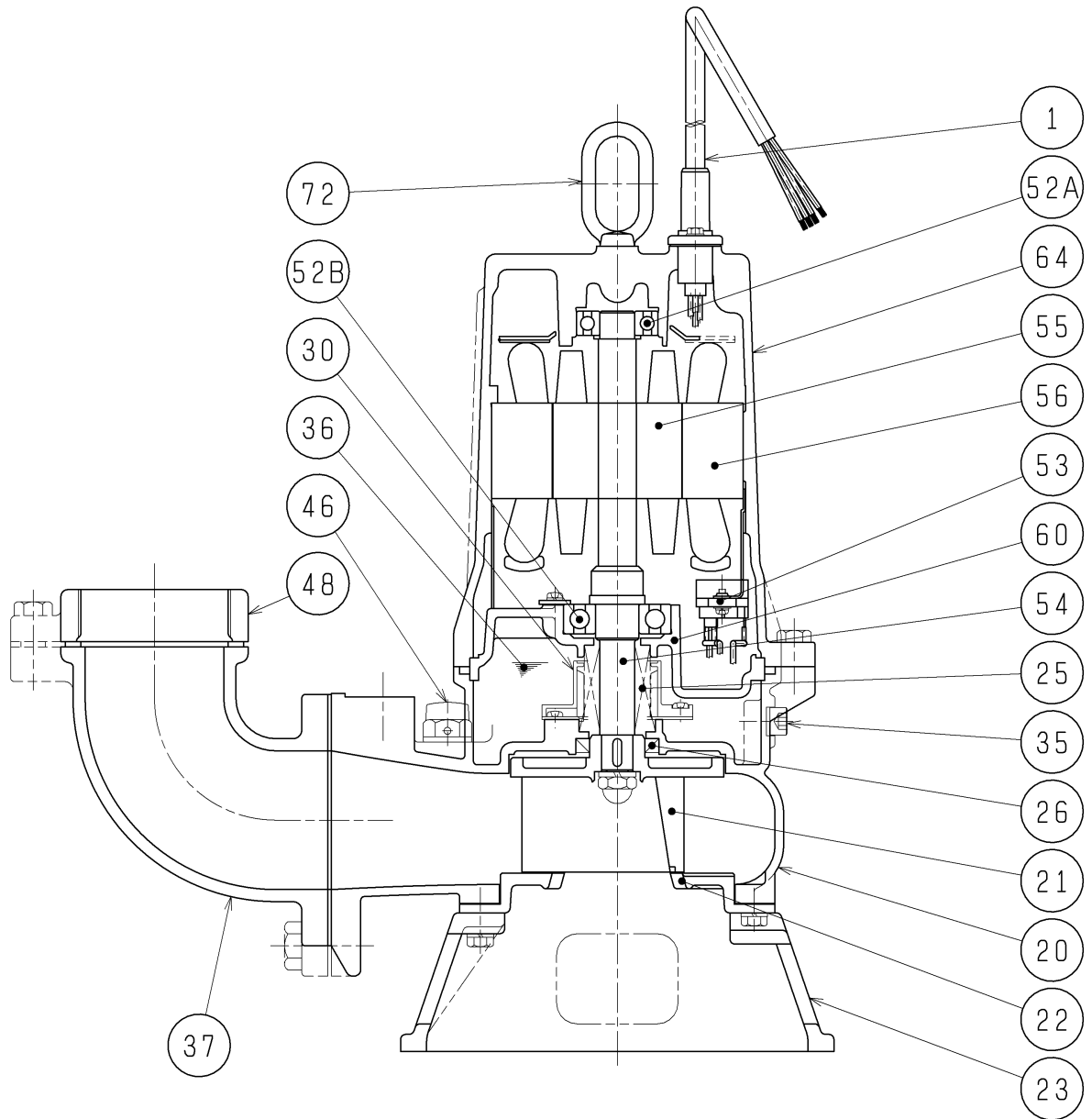

REQ. SPECIFICATION

※ the wetted part

No.	DESCRIPTION	Q'TY	MATERIAL / NOTE	No.	DESCRIPTION	Q'TY	MATERIAL / NOTE
1	Cable	1	PVC Sheath	48	Screwed Flange	1	Gray Iron Casting
20	Pump Casing	1	Gray Iron Casting	52A	Upper Bearing	1	6204ZCC3
21	Impeller	1	Gray Iron Casting(WC Edge)	52B	Lower Bearing	1	6305ZCC3
22	Suction Cover	1	Ductile Iron Casting	53	Motor Protector	1	
23	Strainer Stand	1	Gray Iron Casting	54	Shaft	1	Stainless Steel 420J2(※)
25	Mechanical Seal	1	H-20A	55	Rotor	1	
26	Oil Seal	1	TC32488	56	Stator	1	
30	Oil Lifter	1	Plastic	60	Bearing Housing	1	Gray Iron Casting
35	Oil Plug	1	Stainless Steel 304	64	Motor Frame	1	Gray Iron Casting
36	Lubricant		Turbine Oil (ISO VG32)	72	Eye Bolt	1	Stainless Steel 304
37	Discharge Bend	1	Gray Iron Casting				
46	Air Release Valve	1	Nylon				